

1 2 3 4 5 6 7 8 9 10 11 12

A
B
C
D
E
F
G
H
I
J

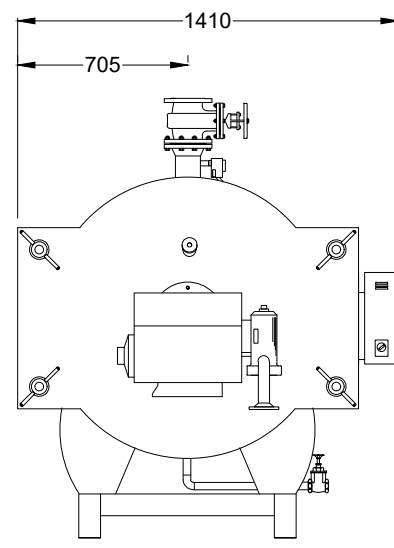
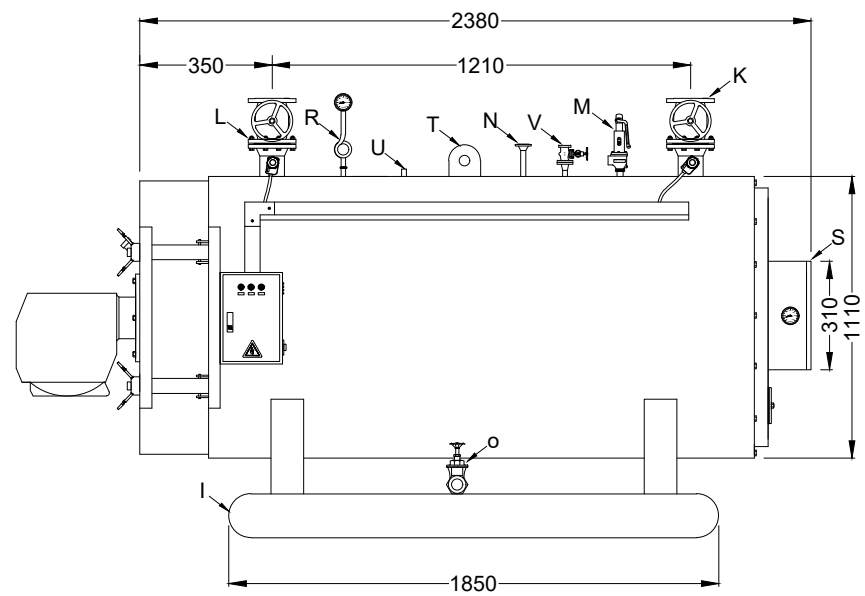
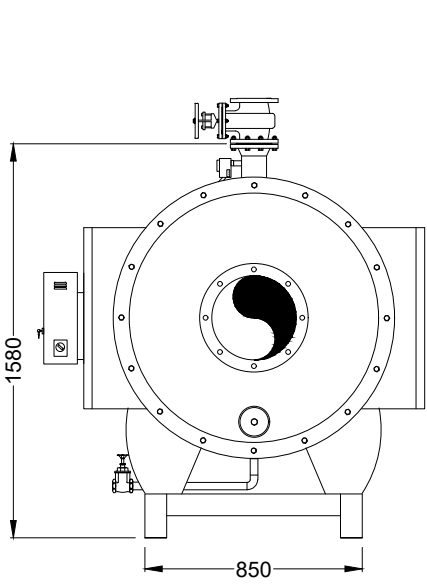

TECHNICAL DATA

DESIGN	
DESIGN STANDARD	BS/EN12953
CAPACITY (kcal/hr)	350,000
WORKING PRESSURE (bar)	
CORROSION ALLOWANCE	0.75 (mm)

MATERIAL	
SHELL & FURNACE	17Mn-4 (DIN 17155)
TUBE SHEETS	17Mn-4 (DIN 17155)
FIRE TUBES	St 35.8 (DIN 17175)
FLANGES	FORGED STEEL ASME B.16.5-150

INSPECTION	
PENETRATION TEST	YES
ULTRASONIC TEST	YES
HYDROSTATIC TEST	YES

CONNECTIONS SIZE		
WATER RETURN	K	2"
WATER OUTLET	L	2"
SAFETY	M	1"
EXPANSION	N	1"
DRAIN	O	1"
STACK Temp. Sensor	Q	½"
TEMPERATURE SENSOR	R	½"
STACK I.D	S	12"
CONTROLLER	U	½"
VENT	V	1"
HAND HOLE	T	65
SKID I-BEAM SIZE(IPN)	I	140

GENERAL NOTE

- 1- ALL DIMENSIONS & ELEVATIONS ARE IN mm.
- 2-THE MAP CONTAINS THE CONSTRUCTION TOLERANCES
- 3-THE MAP PROVIDED IS NOT SCALED. SCALED MAP IS PROVIDED UPON REQUEST.

TITLE:
REVERSE FLAME BOILER DIMENSION DRAWING

DRAFTED	CHECKED	APPROVED	CONFIRMED	REV.	SCALE
				R02	NTS

VENDOR:



PACKMAN
Industrial Group

